

MCCAULEY™

***Professor Von Kliptip Answers
Your Questions About The***

MCCAULEY FULL FEATHERING CONSTANT SPEED PROPELLER GOVERNING SYSTEM

**FOR COUNTERWEIGHTED PRESSURE-TO-
DECREASE PITCH PROPELLERS ON
RECIPROCATING ENGINES**



Professor, what do you mean by "constant speed" system?

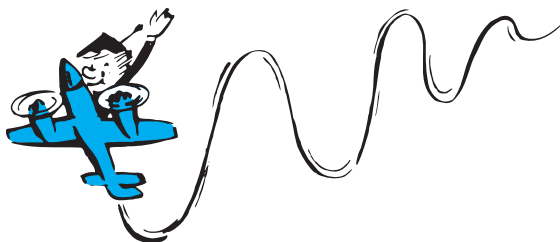

We mean a constant RPM system that permits the pilot to select the propeller - and engine - speed he wants for any situation and automatically maintain that RPM under varying conditions of airspeed and power.

How do you control the RPM?

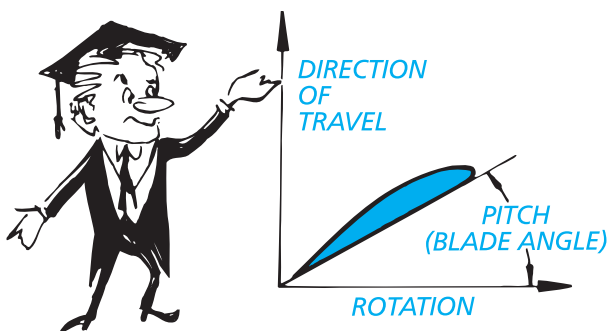

We do it by varying the pitch of the propeller blades. In the sense that we're talking about it, the pitch is the angle of the blades with relation to the plane of rotation. As blade angle is reduced, the torque required to spin the propeller is reduced and, for any given power setting, the airspeed and RPM of the engine will tend to increase. Conversely, if the blade angle increases, the required torque increases. Then, the engine — and the propeller — will tend to slow down. Thus, by varying the blade angle or pitch of the propeller, we can control the RPM.

EDITOR'S NOTE: Don't let the professor's looks fool you. He knows his stuff.

OK, Professor, what is a full feathering propeller?

I'm glad you asked that question. It reminds me to tell you something important: *This system normally is used only on twin-engine aircraft.* If one of the engines fails in flight, you lose power. But worse than that, you could lose control of the aircraft if the propeller on the idle engine is permitted to windmill. To prevent this, we turn the propeller to a very high pitch, so that its blades are almost parallel to the airstream. This prevents windmilling and cuts drag to a minimum. A propeller that can be pitched to this position is known as a full feathering propeller.

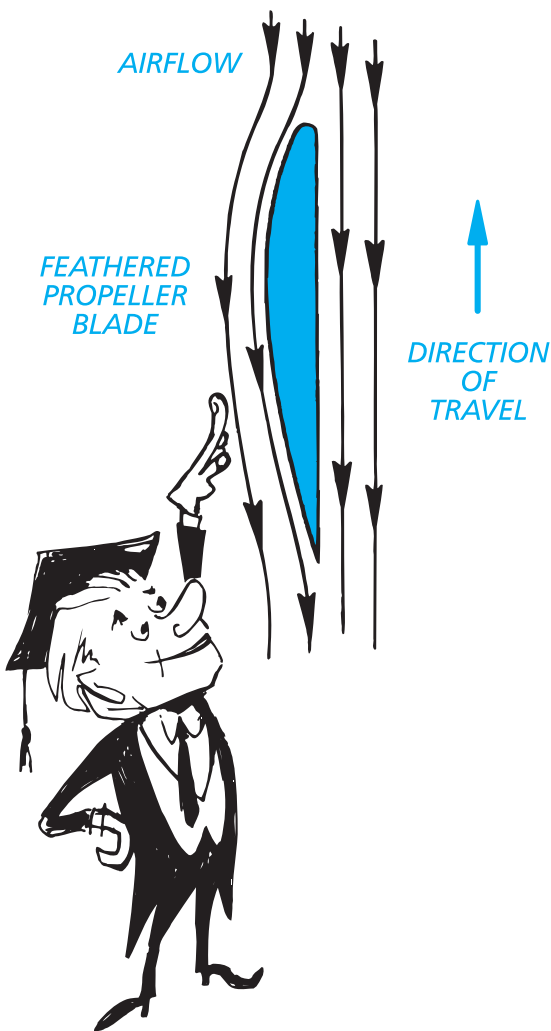

By constant speed, do you mean that the propeller operates at the same RPM all of the time?

Heavens, no! That would never do.

Remember, we said earlier that the system permits the pilot to select the RPM he wants. He has a control for each engine in the cockpit that permits him to do this. When he wants maximum power at low air speed, such as for take-off, he pushes the controls full forward. With full throttle, this gives him low pitch and maximum RPM. This is great for getting off the ground, but it's normally not desirable for cruising at high airspeeds. So for cruising, he can ease back on the throttle and propeller controls. This increases the pitch, and the speed settles into the desired RPM for cruise conditions. The RPM automatically stays set until he moves the controls.

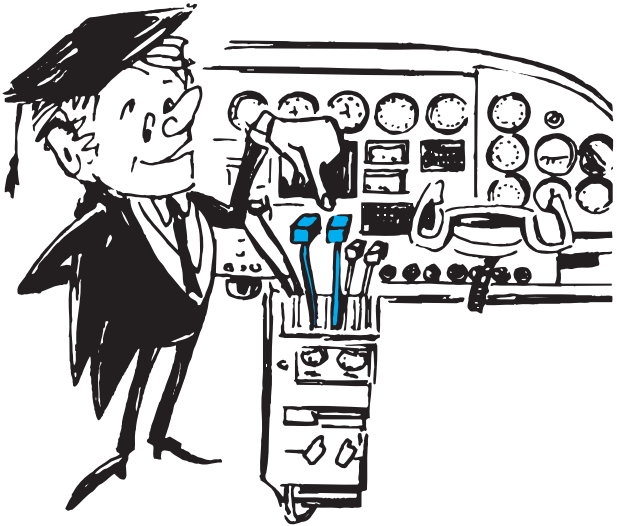

In flight, it is poor practice to put the propellers in feathering position with the engine running — it overloads the engine and really shakes things apart. The controls have detents at the low RPM (high pitch) end to prevent this from happening. The pilot must move the control lever laterally or lift up to get around the detent.

How do you change the pitch of the blades?

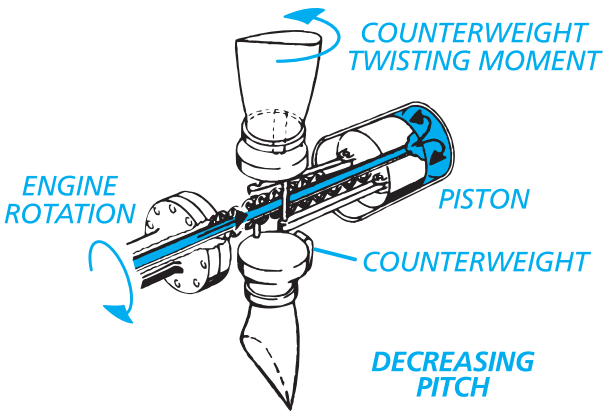

We do it hydraulically in a single acting system, using engine oil from the propeller governor to decrease the pitch of the propeller blades. In the propeller, oil pressure acting on the piston produces a force that is opposed by the twisting moment of the blade counterweights and large springs. To decrease the pitch, we direct high pressure oil to the propeller. This moves the piston back. Motion of the piston is transmitted to the blades through the actuating links and pins, moving the blades toward low pitch.

When the opposing forces are equal, oil flow to the propeller stops, and the piston will stop also. The piston will remain in this position, holding the pitch of the blades constant, until oil flow to or from the propeller is established by the governor.

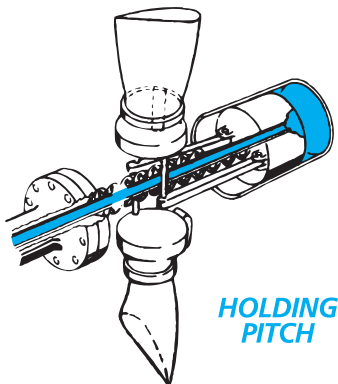

Pitch is increased by allowing oil to flow out of the propeller to be returned to the engine sump. When the governor initiates this procedure, hydraulic pressure is decreased, and the piston moves forward, turning the blades toward high pitch. The piston will continue to move forward until the opposing forces are again equal. If all oil flows out of the propeller, the piston will move forward to the feather stop, and the blades will go to feather pitch. This will happen when the pilot moves the control to the feather position or if oil pressure is lost for any reason.

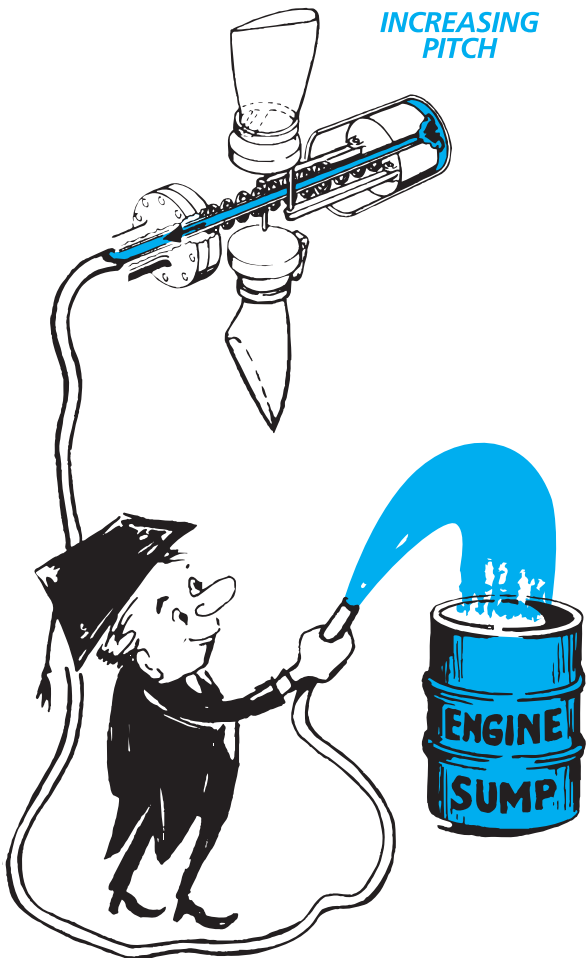

Although they aren't shown in our illustrations, mechanical stops are installed in the propeller to limit travel in both low pitch and feather directions.

How do you prevent the propellers from being feathered when you shut down the engines on the ground?

Don't park near the chicken coop! (Excuse the funny, but I just couldn't resist.)



Seriously, you're showing how alert you are by realizing that you *do lose oil pressure* when you shut the engines down. So, I'll tell you how we do it.

We use a centrifugal latch inside each propeller. This little spring loaded latch is held out of engagement by centrifugal force. When an engine shuts down in the air, the windmilling propeller holds the latch out, and the propeller moves into feather pitch. When the engines are shut down on the ground, the propellers are in low pitch. After shutdown, there is no windmilling. As soon as the propeller speed reduces to about 600 RPM, the spring pulls the latch into engagement. This happens *before* oil pressure is lost. The latch holds the blades at an angle a few degrees above low pitch, so that the engine can be started easily.

So you do it with oil. How, Professor?

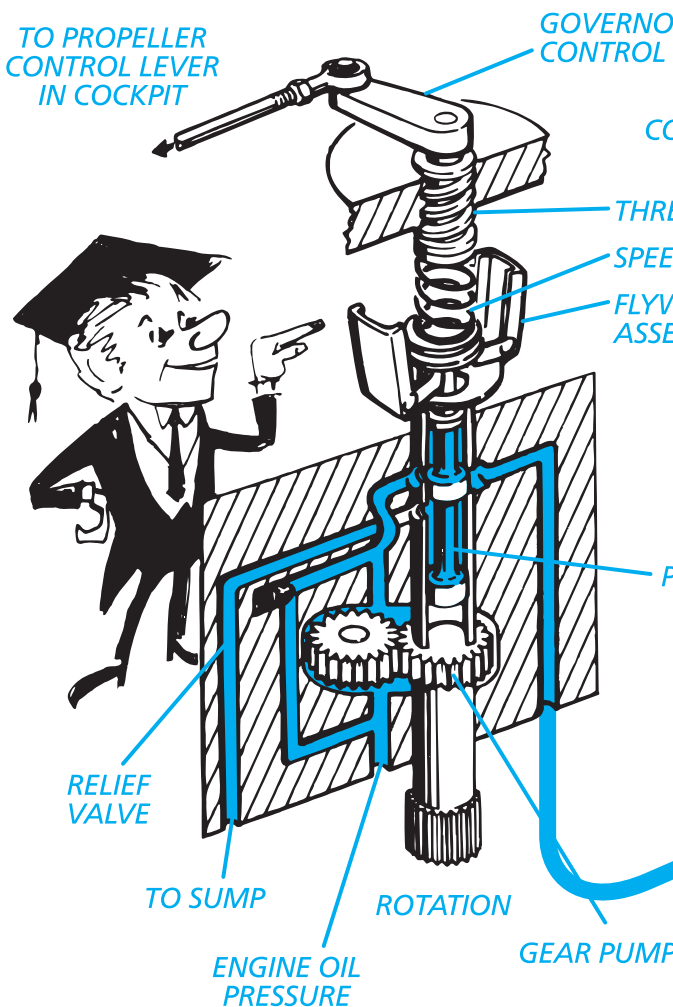

A look at the total system will help to explain this. Besides the propellers, the other major components of the system are the governors, one for each propeller. Each governor mounts on, and is geared to, the engine. This drives the governor gear pump and the flyweight assembly. The gear pump boosts engine oil pressure to provide quick and positive response by the propeller. The rotational speed of the flyweight assembly varies directly with engine speed and controls the position of the pilot

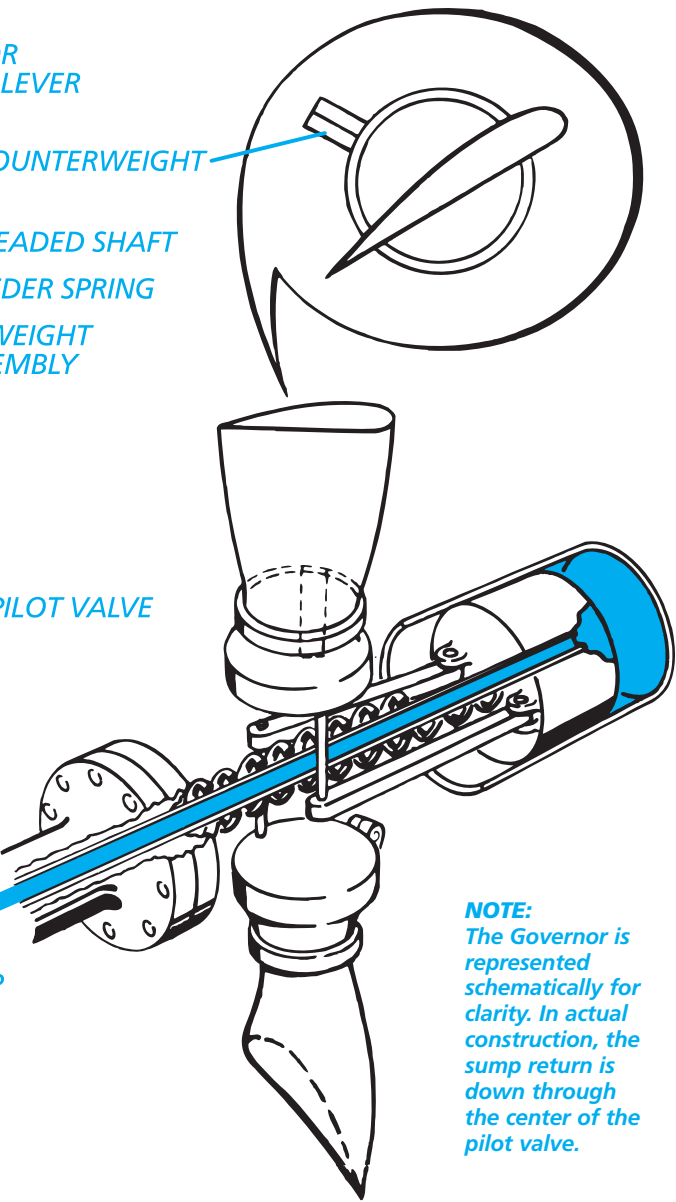

valve. Depending on its position, the pilot valve will allow oil to flow back from the propeller, direct oil flow to the propeller, or assume a neutral position with no oil flow. As we saw earlier, these oil flow conditions correspond to increasing pitch, decreasing pitch, or constant pitch of the propeller blades.

How do the flyweights change the position of the pilot valve?

By utilizing centrifugal force.

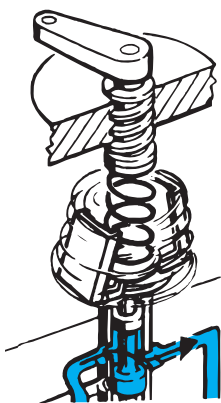

The "L" shaped flyweights are installed with their lower legs projecting under a bearing on the pilot valve. When engine RPM is slower than the propeller control setting, the speeder spring holds the pilot valve down, and oil flows to the propeller.

As engine RPM increases, the tops of the weights are thrown outward by centrifugal force. The lower legs then pivot up, raising the pilot valve against the force of the speeder spring, and there is no oil flow to or from the propeller.

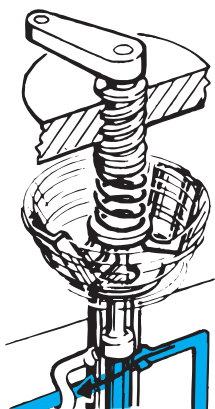
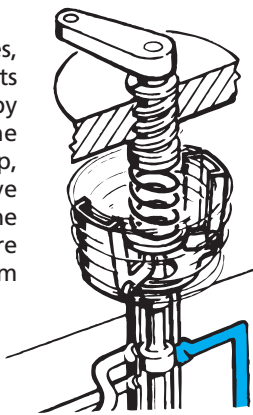

The faster the flyweights spin, the further out they are thrown, causing the pilot valve to be raised and allowing more oil to flow from the propeller.

How does the aircraft pilot control this governor action?

The cockpit control lever for each propeller is connected to the control lever on its governor. The lever is attached to a threaded shaft. As the lever is moved, the threaded shaft turns and runs up or down to increase or decrease compression on the speeder spring.

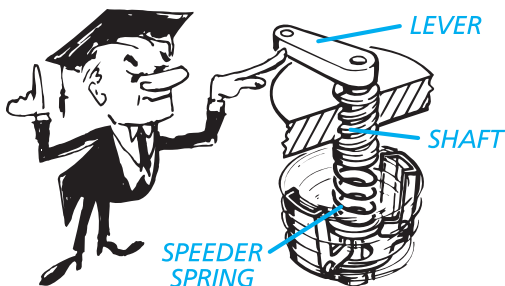

For example, when the cockpit control is moved forward, the governor control shaft is screwed down, increasing compression on the spring. This means that the flyweights must spin faster to raise the pilot valve and results in a higher RPM setting.



When the cockpit control is pulled back, the governor control lever and shaft turn in the opposite direction, relaxing compression on the spring. This reduces the speed necessary for the flyweights to move the pilot valve and produces a lower RPM setting.



Thus, with the cockpit controls, the aircraft pilot can shift the range of governor operation from high RPM to low RPM or any area in between.

So how does all this result in constant speed?

By producing what is known as an ON SPEED condition. This exists when the RPM is constant. Movement of the cockpit controls have set the speeder springs at the desired RPM. The flyweights have positioned the pilot valves to direct oil from or to the propellers. This, in turn, has positioned the propeller blades at a pitch that absorbs the engine power at the RPM selected. When the movement of RPM balance occurs, the force of the flyweights equals the speeder spring load. This positions the pilot valves in the constant RPM position with no oil flowing to or from the propellers.

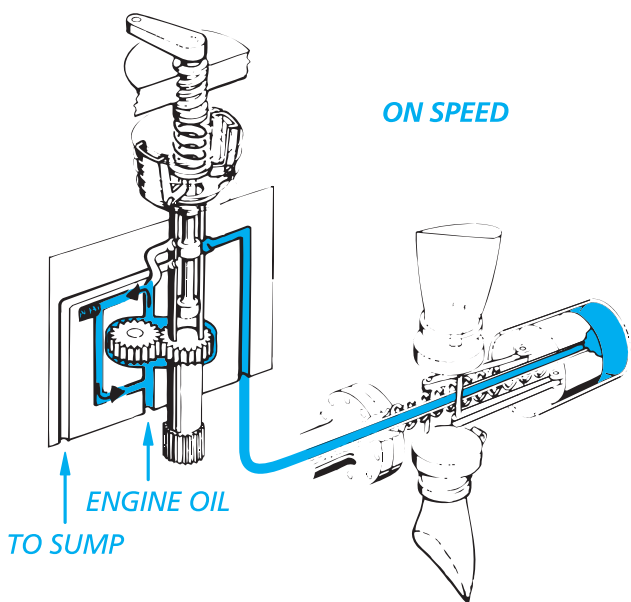

OK, so we're flying along at constant RPM. What happens if the airplane begins to climb or engine power is decreased?

This causes an UNDERSPEED condition. Airspeed is reduced and, since the pitch of the propeller blades is too high, the engines start to slow down. But the instant this happens, the flyweights will droop, causing the pilot valves to move down. Simultaneously, oil flows to the propellers, reducing the pitch of the blades. This automatically increases the speed of the engines to maintain the original RPM setting.

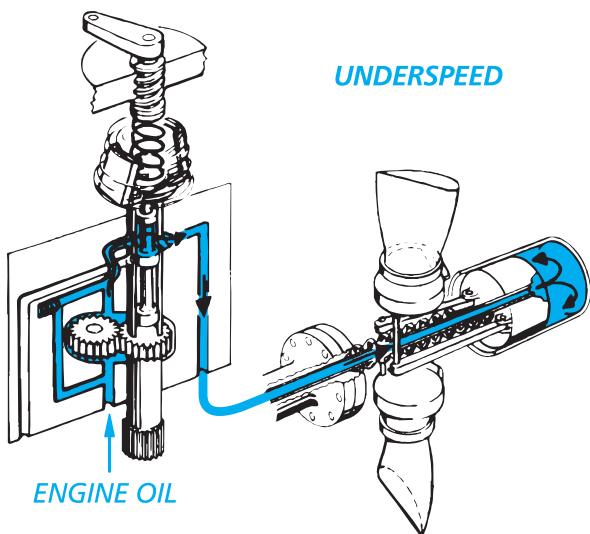

UNDERSPEED

ENGINE OIL

What happens if the airplane goes into a descent or engine power is increased?

This results in an OVERSPEED condition. Airspeed increases. Since the pitch of the propeller blades is too low to absorb engine power, the engine RPM begins to increase. However, the instant this happens, the flyweights move out and raise the pilot valves. This, in turn, causes oil flow to flow from the propellers, increasing the pitch of the blades. Engine speed then slows down to maintain the original RPM setting.

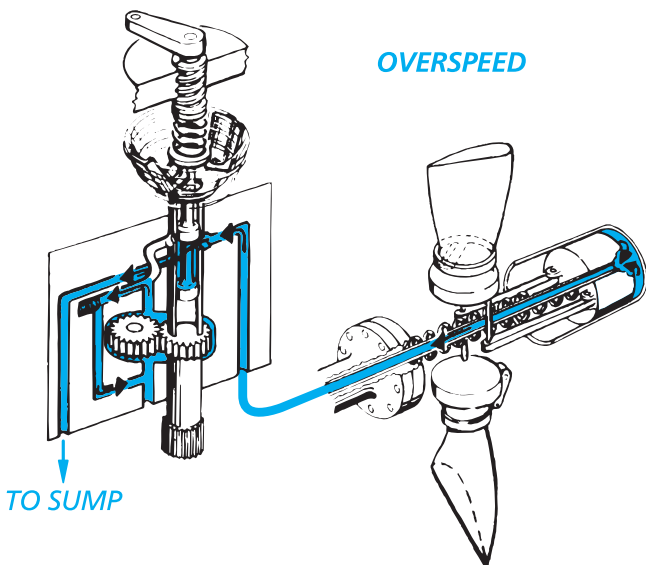

If governor action tends to decrease the pitch with decreasing RPM, how do you manage to feather a propeller?

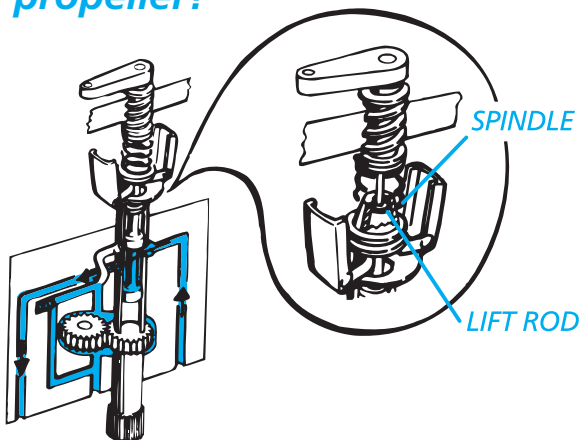

We do it by providing a mechanical linkage that overrides the flyweights and speeder spring. When the cockpit control is moved to feather, the governor lever and shaft are turned beyond normal low RPM operating limits. As the threaded shaft backs out, the shaft lift rod engages the pilot valve spindle and lifts the pilot valve. This causes oil to flow out of the propeller, and it moves to feather pitch.

How do you unfeather a propeller?

Unless the airplane is equipped with the unfeathering accumulator option (I'll tell you about options later), you move the propeller control to high RPM (low pitch) and engage the engine starter. When the engine is turning over fast enough, sufficient oil pressure will be developed to force the propeller blades out of feather.

What about those options, Professor?

UNFEATHERING ACCUMULATOR OPTION

The unfeathering accumulator option will permit a feathered propeller to be unfeathered in flight for air starting the engine. The governor is modified to provide an external high-pressure oil outlet through a check valve and a device for unseating the check valve. The external outlet is connected to an accumulator. One side of the accumulator is filled with compressed air (dry nitrogen) and the other side with oil so that oil can be

stored under high pressure. This is what happens when the aircraft is in normal flight. When the propeller is feathered, the check valve maintains oil pressure in the accumulator. When the propeller control is moved from feather to low pitch, the check valve is unseated, permitting the high-pressure oil in the accumulator to flow to the governor pilot valve. With the governor control lever and shaft in low pitch, the speeder spring forces the pilot valve down so that the oil flows to the propeller and moves the blades to low pitch.

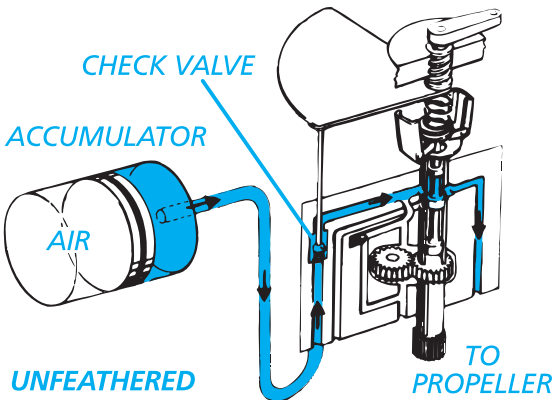
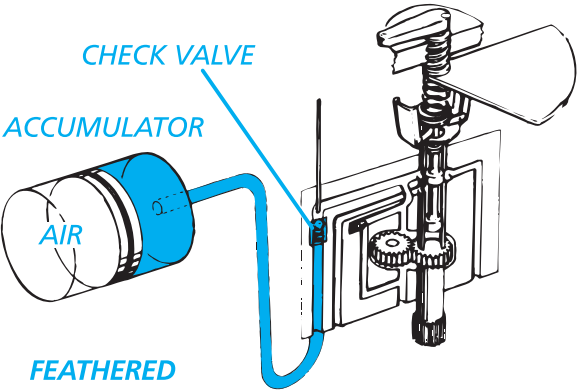
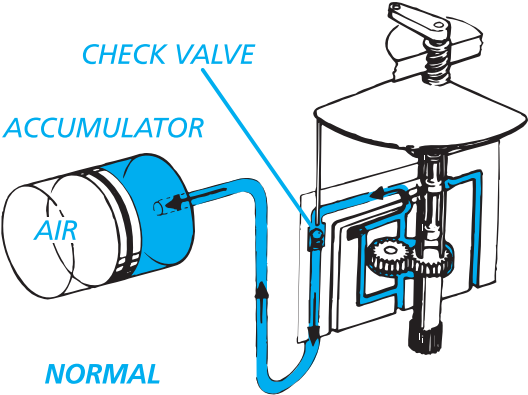

SYNCHRONIZING/SYNCHROPHASING OPTIONS

The governor mechanism provides the means for synchronizing and synchrophasing the two propellers on twin-engine aircraft. The synchronizing option adjusts propeller RPM so that both props are turning at the same speed. McCauley installs a slotted disc on each governor shaft along with a transducer that sends a frequency signal to an electronic control. This control compares the signals from both governors and adjusts one of them to bring it into "synch" with the other.

Once the props are synchronized, the synchrophaser option adjusts the position of the blades on one propeller with respect to the blades of the second prop for reduced noise and vibration. McCauley synchrophasers are solid state units that automatically synchronize prop speed with a phasing control operated by the pilot. This phasing control manually adjusts the difference between the two propellers to minimize the "beat" of the props.



*This booklet is presented in the interest of
happier, safer and wiser flying by*

McCAULEY™

**PROPELLERS • SPINNERS • DEICERS
GOVERNORS & ACCUMULATORS**

5800 E. Pawnee, Wichita, KS 67218

Telephone: 800-621-7767 • 316-831-4021

Fax: 316-206-9948 • www.mccauley.textron.com



McCAULEY™